

ARC WHITE PAPER

By ARC Advisory Group

JANUARY 2005

Yokogawa Unveils VigilantPlant

Executive Overview	3
VigilantPlant Builds on Vigilance Message.....	4
VigilantPlant Incorporates Open and Reliable Network Infrastructure	7
VigilantPlant Provides Advanced Safety System Solution	10
VigilantPlant Alarm Management Strategies.....	15
VigilantPlant Production Management and Optimization Strategies	19
VigilantPlant Provides Path to OpX for Asset Management and Fieldbus	22
VigilantPlant Strengths and Challenges	25



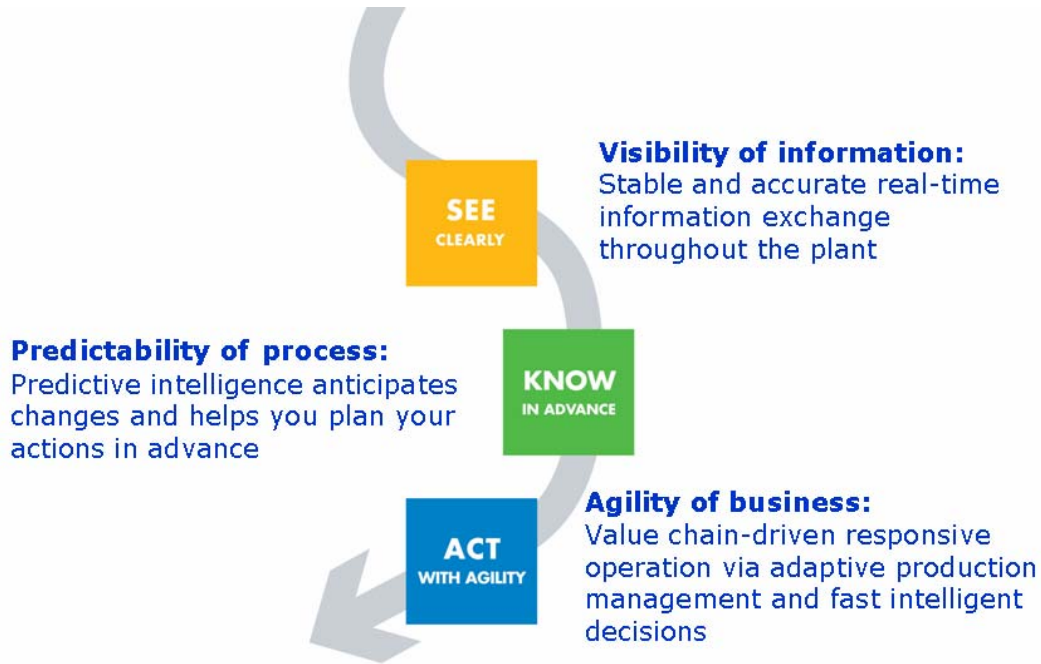

**The Three Primary Components of VigilantPlant:
 Visibility, Predictability, and Action**

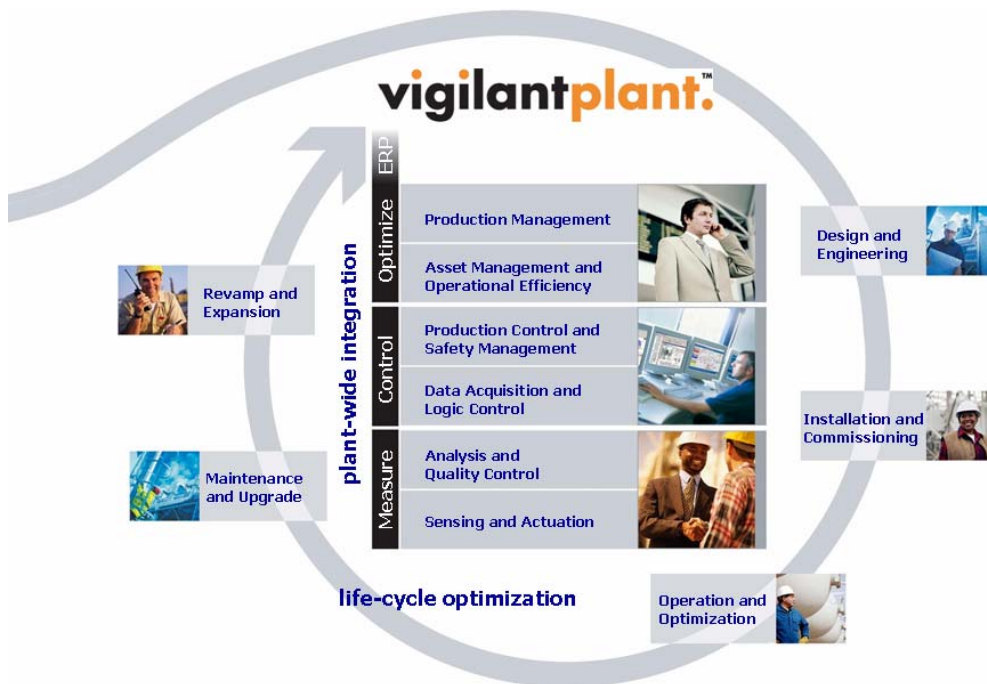

VigilantPlant Brings Together Yokogawa’s Diverse Applications and Domain Expertise to Form a Unified Approach to Knowledge Management

Executive Overview

Yokogawa has come a long way in making its message clear to the world of process automation. Last year, the company embarked on a full-scale global marketing campaign to make customers aware of the company's focus on system reliability, security, dependability, and robustness. Dubbed "Vigilance", the campaign created a unified message for the company and greatly helped expand awareness of the Yokogawa brand and corporate philosophy.

VigilantPlant is essentially a path toward Operational Excellence (OpX) placed in the context of Yokogawa's offerings and capabilities. The core building blocks of the VigilantPlant solution fit well into the model of operational excellence that consists of a continuous improvement cycle of measurement, control, and optimization.

While the Vigilance campaign was good at articulating the company's philosophy, articulating the value proposition of the company's product, application, and services offering remains a key challenge for the company. In 2005, Yokogawa began a campaign

called VigilantPlant, which is designed to raise customer awareness of Yokogawa's solution set and where it fits in the Vigilance scheme. VigilantPlant is essentially a path toward Operational Excellence (OpX) placed in the context of Yokogawa's offerings and capabilities.

The core building blocks of the VigilantPlant solution fit well into the model of operational excellence that consists of a continuous improvement cycle of measurement, control, and optimization. At the measurement level, VigilantPlant includes Yokogawa's solutions for analysis, quality control, sensing, and actuation. The Control domain encompasses Production Control and Safety Management as well as data acquisition and logic control. The optimization domain within VigilantPlant consists of production management, advanced control, asset management, and operational efficiency.

While the VigilantPlant encompasses all of Yokogawa's products and services, there are several key offerings from the company that embody VigilantPlant that are either new and emerging offerings or are simply not as well understood by the end user community. These key offerings are analyzed in this report, and include the ProSafe-RS safety system, the Vnet/IP control network based on Gigabit Ethernet, Yokogawa's alarm management and production management capabilities, and its expertise in fieldbus and plant asset management (PAM).

VigilantPlant Builds on Vigilance Message

Yokogawa has come a long way in making its message clear to the world of process automation. Last year, the company embarked on a full-scale global marketing campaign to make customers aware of the Yokogawa's focus on system reliability, security, dependability, and robustness. Dubbed "Vigilance", the campaign created a unified message for the company and greatly helped expand awareness of the Yokogawa brand and corporate philosophy. Vigilance is successfully increasing brand awareness

Our commitment



A Yokogawa Commitment to Industry
vigilance®

Your future



vigilantplant™
The clear path to operational excellence

VigilantPlant Provides a Concrete Path to Operational Excellence

and communicating Yokogawa's message of reliability and quality to the worldwide market, particularly outside of Japan.

While the Vigilance campaign is good at articulating the company's philosophy, articulating the value proposition of the company's product, application, and services offering remains a key challenge for the company. Yokogawa, for example, has long been known for its control systems, field instrumentation,

and fieldbus capabilities. Many customers, however, remain unaware of Yokogawa's capabilities in production management, safety systems, alarm management, plant asset management (PAM), and many other areas. In 2005, Yokogawa began a campaign called VigilantPlant, which is designed to raise customer awareness of Yokogawa's solution set and where it fits in the Vigilance scheme.

VigilantPlant Gives Substance to Vigilance Philosophy

VigilantPlant is essentially a path toward Operational Excellence (OpX) placed in the context of Yokogawa's offerings and capabilities. Yokogawa's vision with VigilantPlant is to create an environment where plant personnel and operators are well-informed, alert, and ready to take action. Pending abnormal events are detected well before they become a problem, and the role of the operator can be transformed from reacting to problems to mak-

ing intelligent decisions about the process to optimize plant and business performance.

The VigilantPlant philosophy eliminates unplanned downtime and allows businesses to adapt and change quickly and with agility to shifting market conditions and customer demands. This is consistent with ARC's view that giving personnel access to the right information at the right time combined with the ability to take action is crucial for achieving OpX and is the foundation of real time performance management (RPM).



Yokogawa Breaks the VigilantPlant Strategy into the Three Basic Components of See, Know, and Act

Yokogawa breaks the VigilantPlant strategy into the three basic components of See, Know, and Act. To “See” means that there is clear visibility of plant information in the form of stable and accurate real-time information exchange throughout the plant. To “Know” means that predictive intelligence anticipates changes and helps users plan actions in advance. To “Act” with agility means an ability to make decisions quickly and accurately based on the information provided in steps one and two.

The core building blocks of the VigilantPlant solution fit well into the six-sigma model of operational excellence that consists of a continuous improvement cycle of measurement, control, and optimization. At the measurement level, VigilantPlant includes Yokogawa's solutions for analy-

sis, quality control, sensing, and actuation. The Control domain encompasses Production Control and Safety Management as well as data acquisition and logic control. The optimization domain within VigilantPlant consists of production management, asset management, and operational efficiency.

While the VigilantPlant encompasses all of Yokogawa’s products and services, there are several key offerings from the company that embody VigilantPlant that are either new and emerging offerings or are simply not as well understood by the end user community. These key offerings are analyzed in this report. The first component is Yokogawa’s new Vnet/IP open, Ethernet-based networking technology provides the common information infrastructure that is necessary to achieve the vision of CPAS that ARC espouses, and provides a common backbone for information exchange across all VigilantPlant component. Yokogawa’s ProSafe-RS is the company’s new approach to safety and critical condition management.

Cutting vertically across the control and optimization domains is Yokogawa’s new solution for alarm management called AAASuite, which is presented in this report. Yokogawa’s offerings at the production management/MES level are a crucial part of the company’s offering for production optimization, and are often underestimated or misunderstood. In the sensing and actuation domain, Yokogawa’s offerings for fieldbus technology are an essential component, and go hand in hand with the company’s capabilities in plant asset management (PAM) at the optimization level.

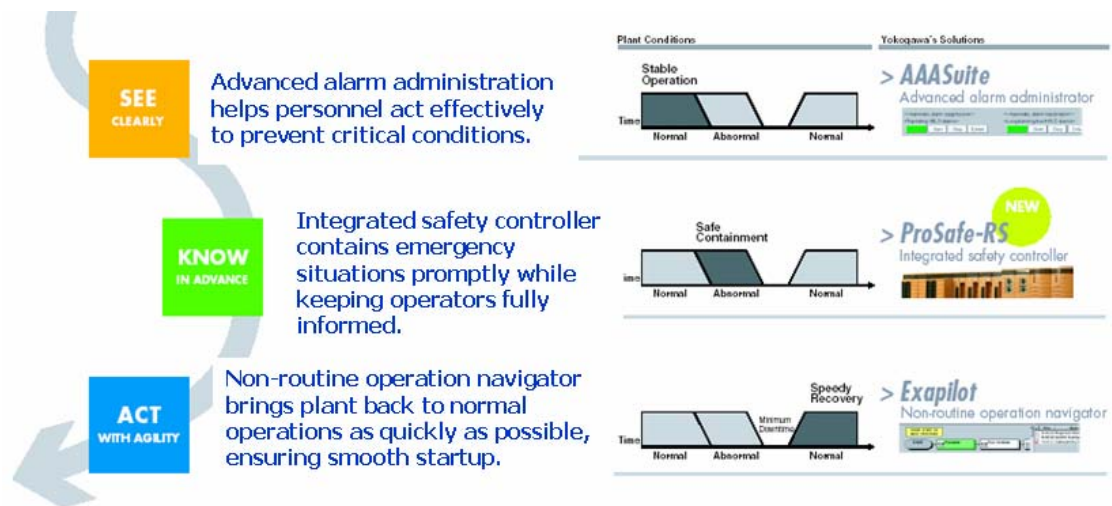

VigilantPlant’s Approach to Plant Safety Encompasses AAA Alarm Management Suite, ProSafe-RS Safety System, and Exapilot Non-Routine Operation Navigator

The VigilantPlant process of See, Know, and Act is ultimately a way to achieve OpX in specific aspects of plant operations. For achieving OpX in plant safety, for example, the AAASuite alarm management offering fills the role of giving operators improved visibility into the alarming scheme of the plant by eliminating unnecessary alarms and giving users improved visibility into abnormal situations as they develop so they can take action before there is an incident. The Know phase is addressed by the ProSafe-RS safety system, which controls safety operations and enable preventive action to be taken. The Exapilot Non-Routine Operation Navigator fills the Act role by bringing operations back to normal as quickly as possible. If there is a shutdown, Exapilot will minimize downtime and ensure a smooth re-startup.

VigilantPlant Incorporates Open and Reliable Network Infrastructure

One of the key areas where Yokogawa is making innovations to its control system infrastructure is in control networks. Today, Yokogawa offers a dedicated protocol that ensures high levels of reliability and real-time functionality in the form of Vnet, which filled many of the requirements that commercially available networking could not fill at the time of its release. Vnet is designed to be deterministic, high-speed, reliable, and secure, with the ability to be deployed in large-scale implementations.

Widespread availability and increasing reliability and determinism of Ethernet-based networks, however, has eroded the base for proprietary control networks considerably, and most suppliers have switched to Ethernet-based control networks over the past several years.

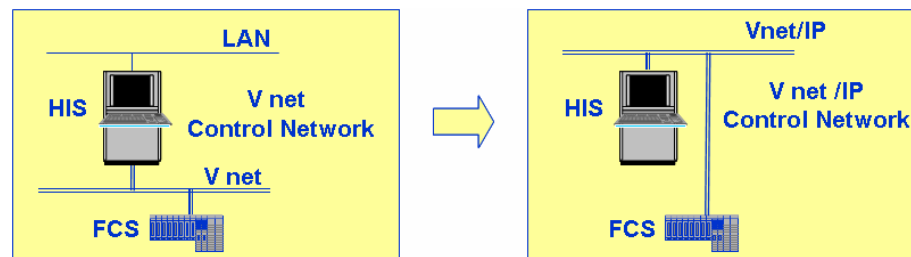

Vnet/IP Collapses CENTUM CS 3000 Control Network Architecture

Ethernet holds significant potential to deliver bottom-line savings in industrial automation. While ability to leverage the commercial sales volume and supply availability in the commercial market is favorable to some, use of this common platform to enable even further capabilities such as remote monitoring & diagnosis, global data availability, and ultimately a truly distributed automation environment is where the true value proposition of the future lies. While Vnet is stable, deterministic, and reliable, it lacked the openness and promise of global data availability promised by Ethernet.

Vnet/IP Brings Yokogawa into the Ethernet Age

Yokogawa's answer to incorporating open networking technology in its systems comes with the release of the Vnet/IP control network, which is available in the latest major version release of the CENTUM CS 3000 control system. The first widely available PAS control network based on Gigabit Ethernet, Vnet/IP offers redundant communications and communications band partitioning over standard Ethernet, while providing the high reliability and deterministic response required for process automation. Vnet/IP offers ten times the throughput of Vnet, and routers are available that can switch between Vnet and Vnet/IP.

The openness of Vnet/IP makes it easier for user to connect non-CENTUM components to the control network through Vnet/IP's TCP/IP communications capabilities and enable users to configure their networks with commercially available network equipment. Data from third party devices can be integrated with CENTUM CS 3000 through the GSGW process data server on Vnet/IP.

Since Vnet/IP is Ethernet-based, users have the ability to choose from a wide range of hardware, and Yokogawa does not specify which hardware vendors are to be used. Yokogawa has, however, certified and tested Cisco and Dell hardware for Vnet/IP, which is consistent with the Ethernet-based offerings of many other PAS suppliers.

Vnet/IP Enables Remote Operations

The value proposition of Ethernet lies primarily in the openness it provides, both within the plant or factory and beyond. Yokogawa understands this and sees Ethernet as an enabling technology. A key area where Yokogawa feels that Vnet/IP provides a business benefit is remote monitoring and operations. Wireless devices, mobile computers, and additional HMI sta-

tions can be deployed from anywhere off the Vnet/IP network. Yokogawa is already offering solutions that allow operators to use Pocket PC-based PDAs and have access to HMI workstation functionality while roaming the plant.

Migration and Coexistence with Vnet Protocol

While Vnet/IP collapses the communication architecture within the CENTUM architecture, unifying the control and information bus, Yokogawa still plans to offer and support the Vnet protocol, and plans on coexistence between Vnet and Vnet/IP. Both protocols can exist in the same system through network partitioning. CENTUM users can migrate to Vnet/IP in a phased manner, and migration to Vnet is a subcomponent of the overall CENTUM V and CENTUM XL migration plan to CENTUM CS 3000 with no changes in field wiring.

Vnet Compatibility with FOUNDATION Fieldbus Networks

HSE has emerged as the high-speed network for FOUNDATION Fieldbus, and Yokogawa offers HSE linking devices for connecting multiple H1 FOUNDATION Fieldbus segments and for high-speed fieldbus control applications. The core control network technology for Yokogawa, however, will remain Vnet/IP. HSE linking devices will be able to interface with Vnet/IP networks.

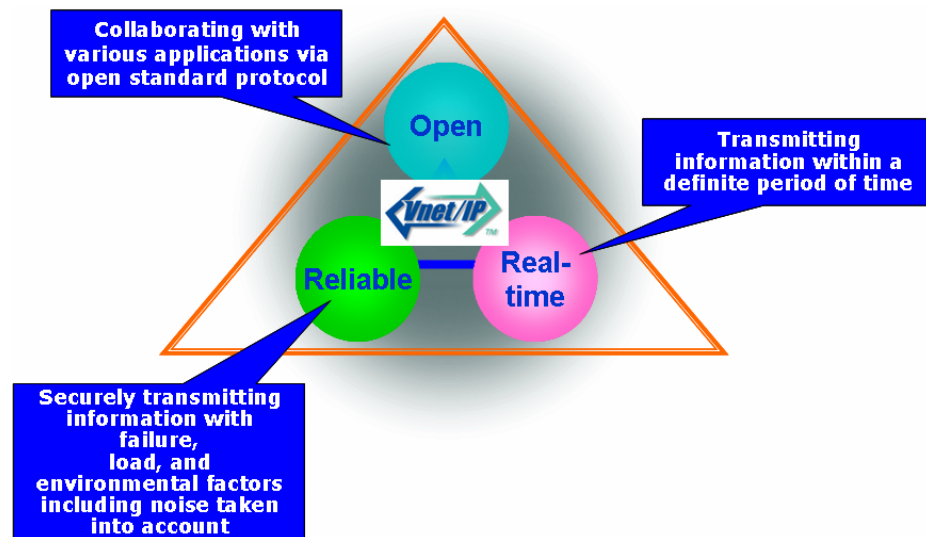

Vnet/IP Combines Reliability and Real-time Performance with Openness of Ethernet

VigilantPlant Provides Advanced Safety System Solution

A significant component in the VigilantPlant scope of offerings is Yokogawa's new approach to safety systems and safety instrumented systems (SISs). Yokogawa is undergoing a major repositioning and evolution of its

Yokogawa is undergoing a major repositioning and evolution of its safety system business to fulfill the vision of VigilantPlant and provide users with increased visibility into plant operations and the ability to take action before problems arise.

safety system business to fulfill the vision of VigilantPlant and provide users with increased visibility into plant operations and the ability to take action before problems arise.

Yokogawa already has a long history in the safety system market. In 1997, Yokogawa acquired Netherlands-based safety systems supplier GTI Industrial Automation (GTI-IA), which specialized in supplying safety systems to the refining, oil & gas, nuclear power, and chemical industries. Yokogawa has since changed the name of the company to Yokogawa Industrial Safety Systems.

Yokogawa's current safety system offering, ProSafe, consists of the ProSafe-SLS and ProSafe-PLC product lines. ProSafe Safety Systems offer all the Safety Integrity Levels from SIL 1 to SIL 4 for the oil & gas, petrochemical, chemical, pharmaceutical, and power industries and integration of safety systems with process control systems. Yokogawa is also a major reseller of Triconex and HIMA safety systems.

ProSafe-RS Fulfills Integrated Safety System Vision

Yokogawa's new approach to safety systems addresses the company's belief that safety systems still lack much of the advanced functionality found in DCSs, such as a unified architecture, integrated HMI, and integrated alarming capabilities, all of which provide the business value proposition of reduced unplanned downtime, lowered total cost of ownership, and increased return on assets.

The new system, called ProSafe-RS (Responsive Solution), will be released for shipment around the end of the second quarter in 2005 with full TÜV certification for SIL 1, 2, and 3 upon release. ProSafe-RS will feature a unified architecture with the CENTUM CS 3000 system. ProSafe-RS fulfills ARC's Critical Condition Management (CCM) vision of "separate yet inte-

grated” safety systems, where the safety system is logically separated from the process automation system, but both are integrated into one system.

A key aspect of ProSafe-RS is its incorporation of the common hardware platform found in the CS 3000 control architecture. CS 3000 is known for being one of the most reliable systems in the industry, and Yokogawa has long specialized in making control systems that are highly reliable and offer a high degree of redundancy and fault tolerance for use in critical process applications such as refining and petrochemical. The CENTUM control system, for example, has an extremely high availability rate of “seven nines”, or 0.999 999 953 availability.

ProSafe Safety Controllers and I/O are provided in the same form factor as CS 3000 hardware, fitting into the same size racks as CS 3000. A dual redundancy system, ProSafe-RS incorporates the same “Pair and Spare” CPU architecture as CS 3000, with redundant CPU, I/O modules, and control networks. SIL 3 compliance is achieved in a single modular architecture, with a single input, output, and control module with a redundant CPU in each, redundant memory in the CPU, and redundant circuits in the I/O.

High availability is achieved in redundant pairs of the already redundant CPUs and I/O. ProSafe is highly scalable from 50 I/Os in a single CPU rack to 1,000 I/Os for a CPU rack and I/O racks to fully distributed systems consisting of 64 stations in a domain of up to 100,000 tags.

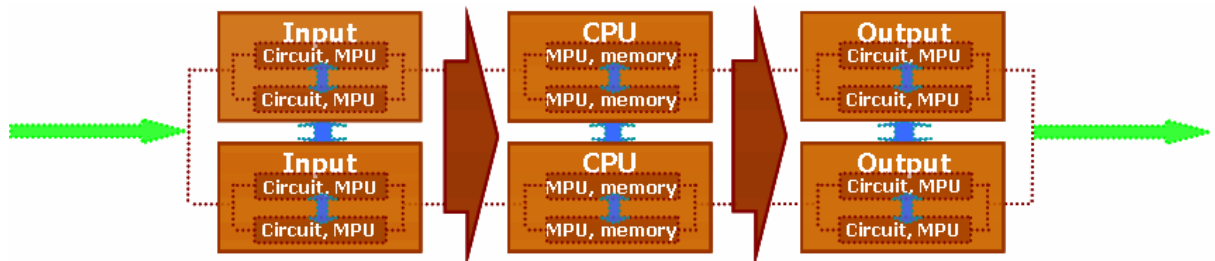

ProSafe-RS Pair & Spare Redundant CPU Scheme

Common Infrastructure for Safety and Regulatory Control

The common hardware and I/O platform shared by ProSafe-RS and CENTUM CS 3000 ensures high quality due to Yokogawa’s ability to make large amounts of CENTUM hardware effectively. The common platform provides seamless data access to the CS 3000 control system through the

common Vnet control network backbone. Yokogawa plans for ProSafe to be compatible with its new Vnet/IP Ethernet-based control network in the near future.

The common network infrastructure facilitates information exchange between the DCS and safety system without the need for an interface module. Separate configurations are also available on separate networks. There is data access to CENTUM FCS controllers as well, with no interface required. Write access to safety controllers from FCS CENTUM controllers will be available under the TÜV certified methodology. This physical integration with the process automation system with logical separation for safety system functionality is the foundation for ARC's CCM vision.

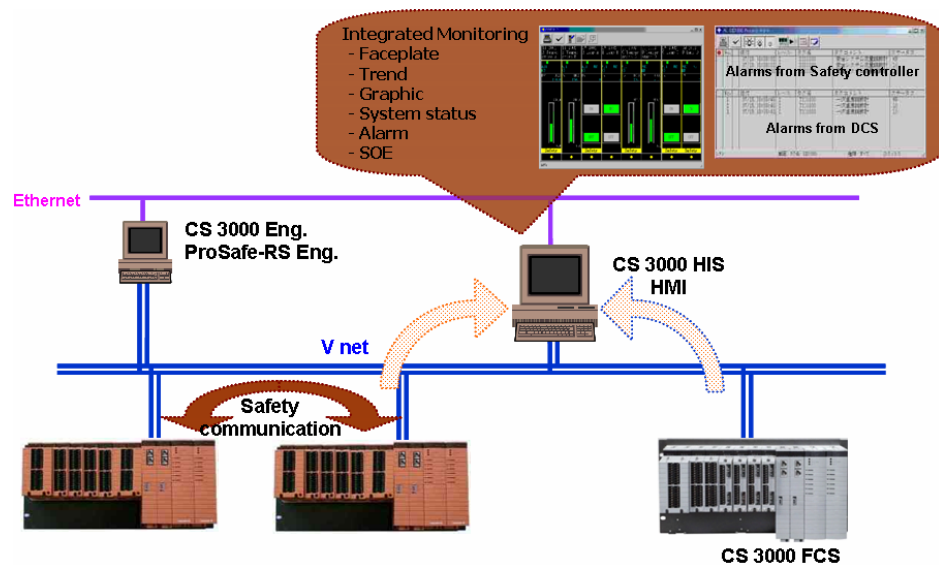

ProSafe-RS Provides Access to Safety Data from CS 3000 HIS

ProSafe-RS and CENTUM CS 3000 share some common software elements, and data from both control and safety systems can be accessed through the CENTUM engineering and HMI stations. Safety and control configuration, however, are accomplished using separate tools with separate security and access control.

Testing, self-documentation, and version control features are also included. The system features logic and system status display, a diagnostic dialog viewer, and allows for forcing variables and online partial logic modification.

ProSafe-RS Embraces Safety Standards

In ARC's view, the incorporation of international standards in automation systems is a solid value proposition and provides users with enhanced functionality and a wider range of choices. Yokogawa has embraced existing and emerging standards for safety and control with ProSafe-RS. For example, the system features an IEC 1131-compliant engineering environment, which incorporates function blocks and ladder logic. Yokogawa is committed to execute and deliver safety system projects according to the IEC 61508/61511 standards. An IEC 61508 compliant Functional Safety Management System is already in place at the company, and a dedicated team of functional safety specialists assure conformance to these standards throughout the company.

Continued Support of Legacy Safety Systems

Yokogawa's commitment to supporting legacy systems has always been strong, and this is no exception with its safety system offerings, particularly for SIL 4 applications. In Yokogawa's view, the ProSafe-SLS and ProSafe-PLC solutions will continue to be a key component of its safety system offering. Although ProSafe-RS is the company's primary safety system platform moving forward, the company states that as of now there is no end of sale or end of support planned for the company's existing safety systems.

Yokogawa has stated that ProSafe-PLC will be able to coexist with ProSafe-RS, with ProSafe-PLC deployed on Vnet networks with the standard ProSafe-COM interface. Customers will be offered a phased plan for migration of application software from ProSafe-PLC to ProSafe-RS.

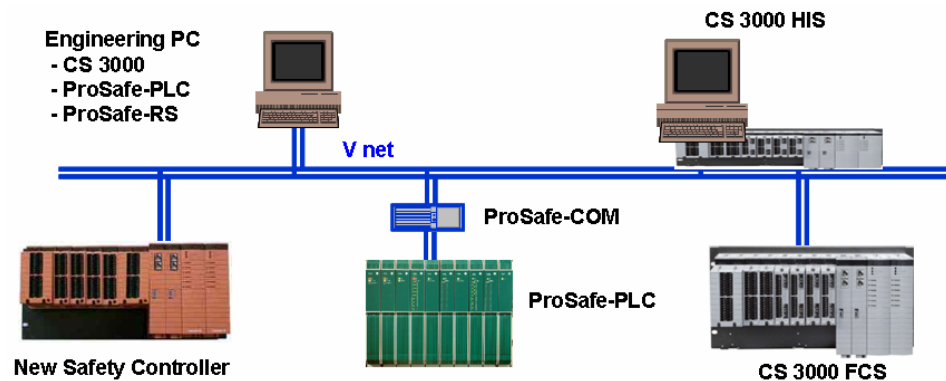

ProSafe-RS Coexistence with ProSafe-PLC

Safety Transmitters Provide Complete SIS Solution

Yokogawa has a line of SIL 2/3-certified safety transmitters that can be combined with its safety systems to create a complete SIS solution. According to Yokogawa, the EJX Series is the first pressure transmitter that comes with TÜV approval as a standard feature. The EJX is compliant with IEC 61508 and IEC 61511 standards for plant safety.

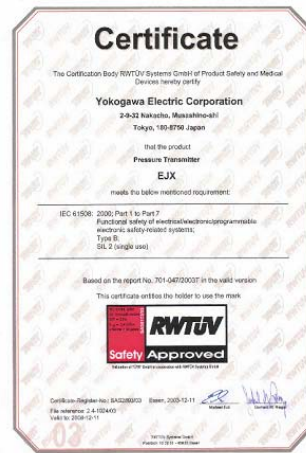

- EJX is SIL 2 approved by TÜV
- EJX is SIL 2 as standard, no option needed
- SIL 3 approved in dual redundant mode

Yokogawa's New Line of SIL2/3 Safety Transmitters are TÜV Certified

ProSafe-RS Strengths and Challenges

Yokogawa's existing position in the safety system market already gives it well-established channels to market. Its large installed base of control systems in industries that are key consumers of safety systems, such as refining, petrochemicals, and oil & gas, are also a key strength. ProSafe-RS' Full TÜV certification and Yokogawa's understanding of local requirements for safety systems in Europe and North America are essential ingredients for success.

The vision of ProSafe-RS as a platform for critical condition management that utilizes a common hardware platform, control network, and software tools is consistent with ARC's vision for CCM and OpX. The common framework provides better visibility into the safety system for operators and other plant personnel. For day-to-day operations, ProSafe enables smoother planned shutdowns and improved monitoring and control of state transitions in the plant. All of this enables the value proposition of reduced unplanned downtime, preservation and optimization of plant assets, and reduced TCO.

Yokogawa's primary challenges with ProSafe-RS lay in its ability to execute and its migration path for its installed base of legacy systems. Commitment to release schedules, product features, and its overall vision is essential. Given Yokogawa's history in this regard, this should not be an issue. The more critical issue is the company's ability to provide continued support of legacy systems and a migration path from these systems to ProSafe-RS.

While Yokogawa has stated its intention to become a market leader in safety systems, this too will be a challenge. Currently, the company is the number six supplier of safety systems worldwide, and must surmount the competitive lead of major suppliers such as Triconex and ABB.

Strengths	Challenges
Large installed base of safety system customers	Migration of installed base to new platform
Established Channels to Market	Keeping commitment to release schedule
Large Installed Base in Key Safety System Industries Such as Refining, Petrochemical, Oil & Gas	Attracting new business outside of installed base
Advanced safety system platform	Continued support of legacy platforms

ProSafe-RS Strengths and Challenges

VigilantPlant Alarm Management Strategies

In ARC's view, alarm management is one of the most undervalued and underutilized aspects of process automation today. In most cases, alarm systems do not receive the attention and resources that are warranted. This is understandable, because alarming appears to be a deceptively simple activity. Many plants still use the alarm management philosophy developed by the engineering firm when the plant was built.

Alarm Management solutions consist of a bundle of best practices and tools that enhance operational performance by improving the effectiveness of alarm systems. Most modern Process Automation Systems (PASs) contain alarm management software that allows for grouping of alarms. Not all suppliers, however, offer equally comprehensive alarm management func-

tions. Some alarm management strategies, while comprehensive, may be extremely complex to use.

AAASuite Provides Full Set of Alarm Management Functions

Yokogawa now offers an alarm management solution that focuses on ease of use and provides a full suite of tools and capabilities from basic alarm suppression to dynamic alarm optimization. Called AAASuite, the primary functions of Yokogawa’s new alarm management package are to identify problems with alarms and execute basic remedies, treat causes of alarm occurrence, and eliminate alarm overload. Yokogawa’s substantial engineering services capabilities for alarm management are also part of the AAASuite offering.

Introduction procedure	Key functions	Purpose	Number of alarm occurrence*1
1	Suppression of repeating nuisance alarms	Suppression of nuisance alarms	Drastically decreased
2	Optimization of alarm setting	Reduction of nuisance alarms	Drastically decreased
3	Re-notification of longstanding true alarms	Addition of value-added alerts	Slightly increased
4	Prediction of important alarms	Addition of value-added alerts	Slightly increased
5	Addition of more advanced alarms	Addition of value-added alerts	Slightly increased

Key Features of AAASuite

AAASuite allows users to change the role of the operator by relieving them from the tedious and repetitive tasks of addressing thousands of alarms and give them more time to focus on improving and controlling the process. AAASuite runs on Windows 2000 Server/Professional or Windows XP Professional.

Basic Alarm Management Functionality

AAASuite includes an Advanced Alarm Administrator, which automatically suppresses nuisance alarms with embedded diagnostic logic. Intended tag names and alarm types can be automatically set in this diagnostic logic through an Alarm and Events (A&E) server, eliminating the need for additional engineering work. Users can add and highlight value-adding alarms for quicker decision-making.

AAASuite offers alarm repetition suppression by automatically identifying typical nuisance alarms by analyzing the frequency of their occurrence and

related process data. AAASuite then automatically suppresses nuisance alarm repetition by changing the alarm set point to a stricter setting, or by turning the alarm off. After suppression, AAASuite continues to monitor the relevant tag, and if the situation changes, AAASuite automatically reverts to the original alarm set point or turns the alarm back on. If there is an unexpected shutdown of an AAASuite master PC, the AAASuite recovery PC automatically reverts the suppressed alarms to their original set points or restores the alarms to “on”.

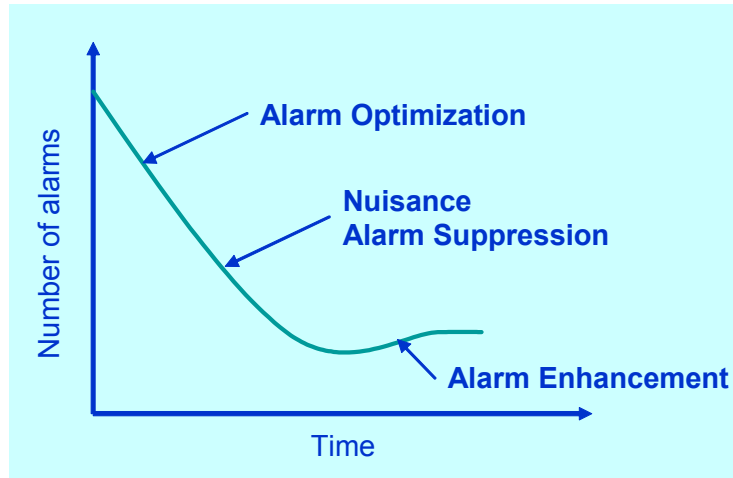

AAASuite Implementation Procedure

Yokogawa Advises Users to Implement AAASuite as Part of a Continuous Improvement Process for Alarm Management

An archive of suppressed alarms, root causes of alarm occurrence, and essential improvement tactics can automatically be stored in reports as audit trails. By analyzing the audit trail, future improvements can be more easily determined.

EVALCA, a major manufacturer and marketer of Ethylene Vinyl Alcohol copolymer resins, has adopted AAASuite along with Yokogawa consulting services at its Texas plant. The company’s primary reasons for choosing to implement an alarm management strategy included avoidance of potential safety or environmental incidents due to alarm overload or missing critical alarms. Ultimately, the company achieved a 93 percent reduction in alarms. Alarms are more meaningful, and operators no longer need to turn alarms off, and the problem of important alarms being turned off has substantially reduced the risk of a major process upset and unplanned downtime, as well as associated safety and environmental concerns. Op-

erators have more time to attend to true process concerns instead of nuisance alarms.

AAASuite Offers Dynamic Alarm Optimization

One of the key challenges facing users in their implementation of an alarm management strategy is the readjustment of alarm set points during state changes in the plant, such as startup or shutdown. AAASuite can dynamically change alarm set points according to changes in operational states. A database of alarm set points can be stored in a CSV file, and AAASuite downloads the appropriate alarm data settings to the DCS automatically when there is a state change. If operators are allowed to change alarm set points manually during operation, AAASuite uploads the current alarm data sets to a CSV format file automatically when the operational state is changed again. AAASuite also provides operators with automatic re-notification of longstanding alarms to prevent possible oversights.

Value-Added Alerts Enhance OpX Proposition

Alarms are often used to trigger an interlock sequence for applications such as emergency shutdown. Operators must detect these alarms before the process reaches the critical point where this interlock is executed, and alarms should be set at the point where the operator has the ability to take action. If alarms are set too conservatively, then they are triggered within normal operating parameters. Conversely, if alarms are set outside the normal operating range of the plant, it is too late for the operator to take action. AAASuite can trigger predictive alerts before the process reaches the shutdown phase. AAASuite provides various kinds of advanced alerts as a template.

ARC believes that alarm management should be approached as a continuous improvement process, and AAASuite offers many tools that allow users to do this. The incorporation of an event analysis tool allows users to create alarm and event logs that can categorize alarms from events, as well as tools to categorize alarm types and itemize tags that cause the most problems.

VigilantPlant Production Management and Optimization Strategies

Yokogawa has a wide range of production management and MES solutions ranging from plant information management systems (PIMS) and advanced process control (APC) to operator assistance solutions. The company's goal with VigilantPlant is to consolidate these offerings under a single unified umbrella. Yokogawa's VigilantPlant model of See, Know, and Act fits nicely into ARC's view of the production management marketplace, which consists of the three-step process of planning, informing, and optimization.

The diversity of Yokogawa's applications in the production management and optimization is partly to blame for their underexposure in the marketplace. Yokogawa divides its production management and optimization applications into five primary groups. The Advanced Operations Assistance (AOA) suite consists of AAASuite alarm management applications, Exaplog event analysis package, and Exapilot operations efficiency package.

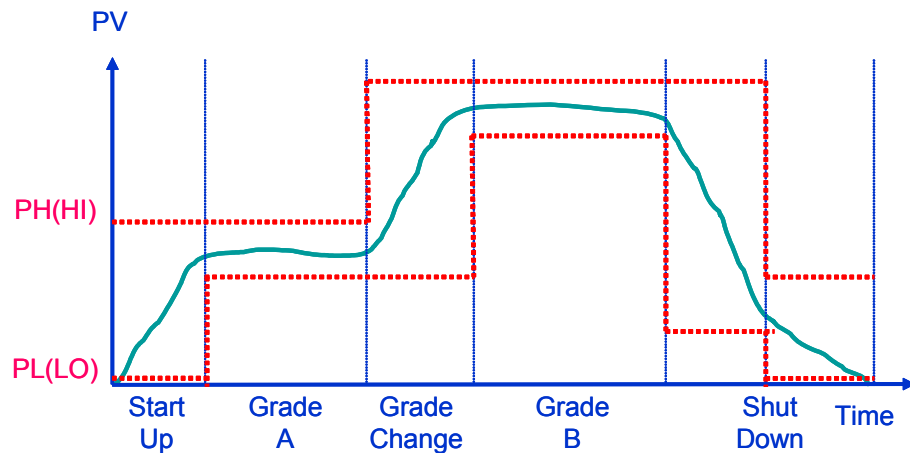

Dynamic Alarm Optimization Adjusts for State Changes in the Process

The AOA suite provides an engineering tool for failure diagnostics, for providing instruction and advice to operators, and for automating procedures, as well as a host of other plant applications. Yokogawa developed the Exapilot package to increase operation efficiency. With Exapilot, by describing the expertise of non-steady-state operations by experienced operators, as a graphical flow diagram of the sequence of actions, the operations can be automated or semi-automated. In addition to Exapilot, the Exaplog event analysis package helps to refine the controllability of a

plant and to identify parts of plant operation that could be improved. AAASuite is the third major component of the AOA suite discussed elsewhere in this report.

Yokogawa’s Advanced Process Control (APC) suite includes the Exasmoc multivariable process controller (MPC), which the company sells through an agreement with Shell Global Solutions. Other applications in the APC realm include Exarqe inferential sensors, Exacoast advanced control toolset, and Exaspot real-time online optimizer.

Yokogawa’s PIMS offerings are represented by the Exaquantum and Exaquantum/Batch applications. Exaquantum is a platform used to acquire data from all facets of a business and the subsequent transformation of that data into easily usable, high-value, widely distributed information. Exaquantum provides automatic database configuration and management by using data from the DCS. Comprehensive, operator specific historization and archiving of many data types is available, as well as statistical process control (SPC) capabilities. Exaquantum/Batch is an S88-based batch control system that provides analysis and reporting facilities that collect, store and display current and historical data from batch production, equipment, and recipe viewpoints.

The Exaopc OPC interface application that allows Yokogawa applications to interface seamlessly with Yokogawa or third party DCSs. Exaopc has passed the OPC Foundation compliance test for Data Access Version 2 (DA2).

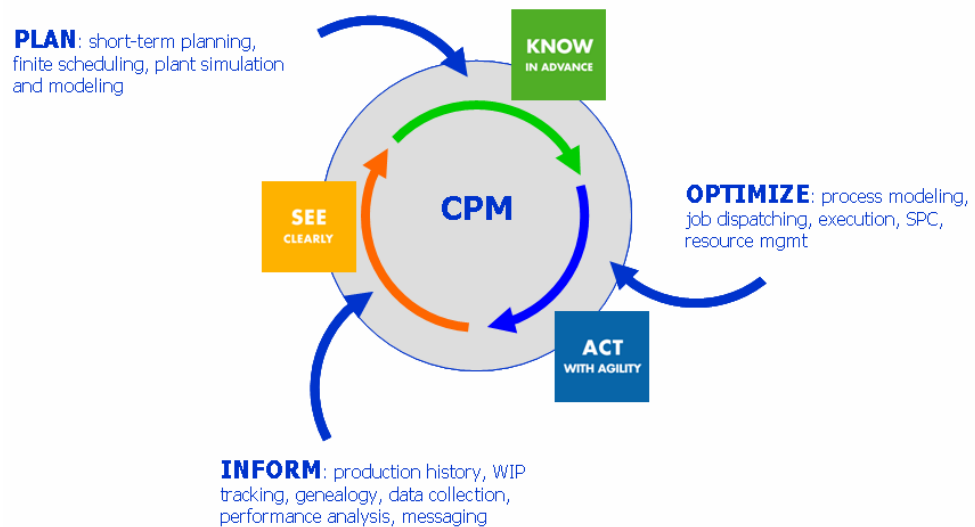

VigilantPlant’s CPM and Optimization Solutions Map to ARC’s Production Management Model of Plan, Optimize, and Inform

Applications packages consist primarily of Yokogawa's oil movement and storage (OMS) applications. fitOMS is a suite of software for refinery offsite operations that runs on Windows workstations or Yokogawa DCSs. It consists of modules such as fitOMS BLEND for blend ration control and fitOMS BPC for blend property control. fitOMS applications help improve refinery productivity by improving throughputs and reducing component costs.

The Exaoms 3000 is an off-site management system that deals with the movement and crude intake from other facilities, movement within the refinery through complex pipeline networks and dispatch of marketable products out of the Refinery. The Exaoms 3000 suite includes all necessary components for Path Generation, Tank Inventory Monitoring, Blending Automation, Supervisory control functions and Automatic Oil Movements monitoring and control.

Product	Product Type
AAASuite	Alarm Management
Exaquantum	Plant Information Management System
Exaquantum/Batch	Batch Control Package
FitOMS/Exaoms 3000	Oil Movement System
Exaopc	OPC Interface
Exatas	Terminal Automation System
Exasmoc	Advanced Process Control
Exacoast	Library of standard advanced control tools
Exaspot	Real-time optimization
Exarqe	Inferential Sensors
Exaplog	Event Analysis Package
Exapilot	Operational Efficiency Improvement Package
Plantutor	Operator Training Simulator

Yokogawa's Production Management and Optimization Applications

VigilantPlant Provides Path to OpX for Asset Management and Fieldbus

Yokogawa has been a leader in fieldbus technology for many years. In addition, Yokogawa offers a full-scale asset management solution in the form of the Plant Resource Manager (PRM) suite of applications. When placed in the context of VigilantPlant, Yokogawa's fieldbus and asset management capabilities provide a path to OpX for predictive field maintenance, from the improved visibility and self-diagnostics capabilities of Yokogawa field devices to the integrated PAM capabilities of PRM to the fieldbus-compatible control capabilities of CENTUM CS 3000.

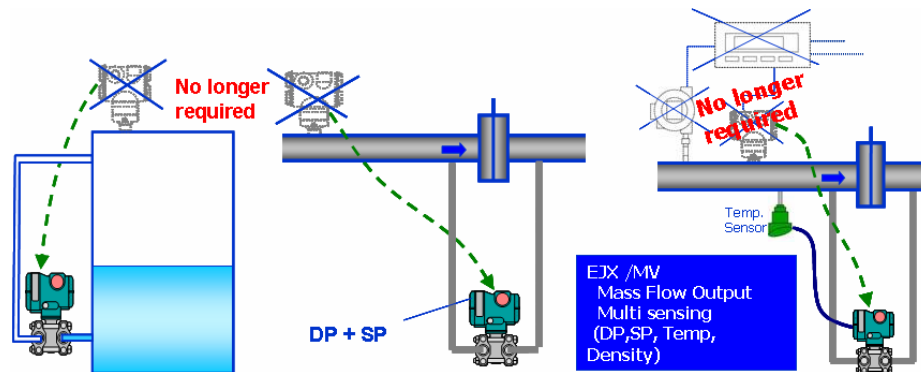

EJX Multivariable Measurement Pressure Transmitters Eliminate the Need for Additional Field Instruments for DP-Based Flow & Level Measurement

Yokogawa's full range of fieldbus and HART-compatible field instrumentation allow users to see more clearly into the health and status of field devices with greater accuracy and dependability. Yokogawa's EJX multivariable measurement pressure transmitters, for example, provide DP-based mass flow measurement through a single transmitter with an inherently digital DPharp silicon resonant sensor that requires no analog to digital conversion.

In addition to differential pressure, EJX can also measure static pressure and ambient temperature. Another unique measurement device offered by Yokogawa is the YEFLO multivariable vortex flowmeter, which enables mass flow measurement of saturated steam and liquids through a single vortex flowmeter. Yokogawa is continuously developing embedded diagnostics in its field devices. Recent developments in embedded diagnostics include predictive detection of plugged impulse lines and steam/electric tracing.

Yokogawa's process analytical offerings further exemplify the company's commitment to delivering intelligent field devices that enable multivariable measurement and advanced diagnostics. The new O2mationAV550 oxygen analyzers manage up to eight oxygen detectors per a single averaging converter. Its predictive Calibration function advises the user of the next calibration timing in advance, and helps optimize the analyzer maintenance cycle. Users can use O2mation's Detector Validation function to do a quick check for the detector conditions. O2mation's Detector Asymmetry Alarm, another unique diagnostics function, monitors the span correction ratio to diagnose and predict filter plugging of the zirconia cell in detector probes.

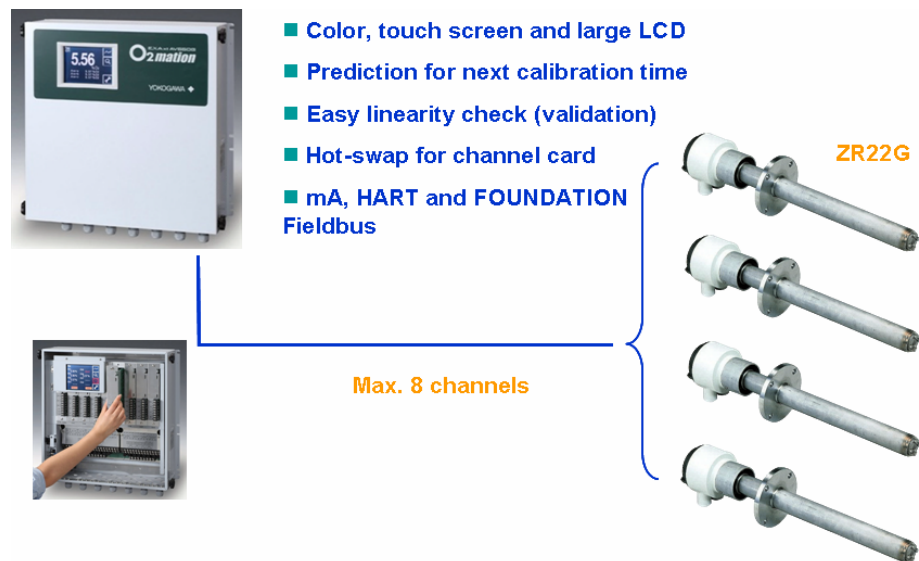

Yokogawa's O2mation Averaging Converter Enables Predictive Diagnostics for Analytical Applications

Yokogawa's Plant Resource Manager (PRM) is a comprehensive asset management solution that provides users with the knowledge of predictive diagnostics. PRM operates across multiple protocols and has the capability to integrate intelligent field device data from a wide range of suppliers. PRM works by collecting maintenance information of devices through standard field protocols and storing this information in a central database. The corresponding maintenance schedules, maintenance procedures, and spare parts information are stored in the same database. The automatic collection and storage of the maintenance data by PRM relieves maintenance engineers from going out to hazardous and remote areas in the field to collect this type of information. PRM can also create a database for legacy devices.

PRM includes audit trail functionality. Audit trail management is important in both control and maintenance systems. All maintenance activities performed on devices maintained by PRM are recorded and stored for fast retrieval during audits. PRM uses Plug-In applications that improve maintenance efficiency. ValveNavi, for example, is a Plug-In that supplies a setup wizard to simplify the tasks of valve start-up and adjustment. DeviceViewer is a plug-in that provides status, device-specific self-diagnosis information, and other diagnostic data for FF-H1 devices.

The CENTUM and Stardom control systems provide the essential “Act” or control functionality in VigilantPlant’s scheme for fieldbus and asset management OpX. CENTUM CS 3000 was the first certified host system for FOUNDATION Fieldbus. CENTUM CS 3000 includes a new I/O subsystem that has been designed to support FOUNDATION Fieldbus fully, with an enhanced ability to handle increasing amounts of communications data and an increased number of fieldbus devices per segment.

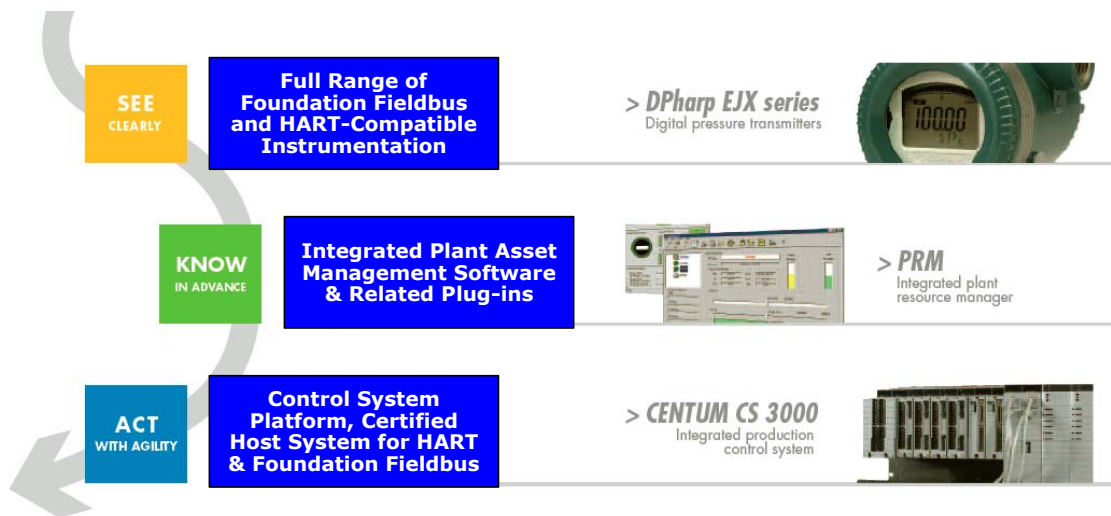

VigilantPlant Provides a Path to OpX for PAM and Field Instrument Maintenance

Yokogawa’s new ALF111 fieldbus interface module is the first interface to allow duplexed fieldbus configurations with bumpless switchover. CENTUM’s engineering capabilities allow users to integrate the control functions implemented in each Field Control Station (FCS) as well as in each of the field devices connected through FOUNDATION Fieldbus. Engineering is further simplified through automatic scheduling of each fieldbus segment. A multi-scheduling function allows a mixture of different execution cycles.

VigilantPlant Strengths and Challenges

VigilantPlant give users a clear path toward OpX by placing its applications and capabilities in the context of a continuous improvement process. VigilantPlant clearly identifies areas of plant operations and maintenance that can be improved, such as plant safety, plant asset management, fieldbus, production management, and optimization. ARC believes that the VigilantPlant philosophy is a good way for Yokogawa to articulate its Vigilance vision into actionable strategies in the plant through Yokogawa products and services.

Yokogawa has improved the articulation of its business value proposition significantly with VigilantPlant, but the company must not stop here. Yokogawa must view the VigilantPlant as a continuous improvement process, and must continue to refine and improve its message. One important next step for Yokogawa is to extend the VigilantPlant message to cover other areas of the plant where operational excellence can be achieved. Showing concrete, industry specific business examples where VigilantPlant offerings have made a bottom line impact on operations is one way on which Yokogawa could strengthen its message.

One of the key enablers to Yokogawa's ongoing success with VigilantPlant is the strength of its basic automation platform, CENTUM CS 3000. The future success of both Vigilance and VigilantPlant depend on the continued evolution of these platforms. With the next major release of CS 3000 coming in the first quarter of 2005, Yokogawa is committed to a consistent evolution of CS 3000.

Many aspects of VigilantPlant have not yet been released. ProSafe-RS and Vnet/IP are two examples of technologies that Yokogawa has recently introduced to the market, and both are crucial elements in the VigilantPlant value proposition. Yokogawa must remain vigilant itself in its commitments to release dates and feature sets for its future products. Another area where Yokogawa needs to continue to focus its efforts is its production management and optimization offerings. Yokogawa has come a long way in consolidating its applications under a single set of solutions, but must continue to unify its offerings & improve its message to the marketplace.

The success of VigilantPlant depends on the success of the Yokogawa's ability to communicate its value to existing and potential customers. ARC has

always believed that Yokogawa offers a good value proposition to users, and the company has a solid foundation of technology that is continuously evolving. Many of the technological “gems” under the Yokogawa umbrella, however, have gone unnoticed because of lack of communication and messaging. VigilantPlant addresses this issue by putting Yokogawa products and services in the context of a path to OpX.

VigilantPlant Strengths	VigilantPlant Challenges
Clear Path to OpX in Context of Yokogawa’s Products	Need to Stay Focused on Message and Remain Consistent
Broad Product, Application, & Service Offerings	Need Continuous Improvement in Communicating Message and Value Proposition
Strong Control System Infrastructure	Continue to Evolve CENTUM and STAR-DOM PAS System Architectures
Open Communications Infrastructure	Vnet/IP not yet Available for Large-Scale Commercial Shipment, Need to Live Up to Commitments and Development Schedule
Strong Safety Management Solution	Need to Live Up to Commitments and Development Schedule for ProSafe-RS
Strong Production Management & Optimization Solutions that Fit Well in VigilantPlant Model	Need to Unify CPM and Optimization Offerings & Improve Message to Marketplace

Yokogawa VigilantPlant Strengths and Challenges

Analyst: Larry O'Brien

Editor: Dick Hill

Acronym Reference: For a complete list of industry acronyms, refer to our web page at www.arcweb.com/Community/terms/terms.htm

AI	Artificial Intelligence	ERP	Enterprise Resource Planning
API	Application Program Interface	HMI	Human Machine Interface
APS	Advanced Planning & Scheduling	IT	Information Technology
B2B	Business-to-Business	LAN	Local Area Network
BPM	Business Process Management	MIS	Management Information System
CAGR	Compound Annual Growth Rate	MRP	Materials Resource Planning
CAS	Collaborative Automation System	OpX	Operational Excellence
CMM	Collaborative Manufacturing Management	OLE	Object Linking & Embedding
CNC	Computer Numeric Control	OPC	OLE for Process Control
CPG	Consumer Packaged Goods	PAS	Process Automation System
CPAS	Collaborative Process Automation System	PLC	Programmable Logic Controller
CPM	Collaborative Production Management	PLM	Product Lifecycle Management
CRM	Customer Relationship Management	ROA	Return on Assets
EAI	Enterprise Application Integration	ROI	Return on Investment
EAM	Enterprise Asset Management	RPM	Real-time Performance Management
		SCE	Supply Chain Execution
		WAH	Web Application Hosting
		WMS	Warehouse Management System

Founded in 1986, ARC Advisory Group has grown to become the Thought Leader in Manufacturing and Supply Chain solutions. For even your most complex business issues, our analysts have the expert industry knowledge and firsthand experience to help you find the best answer. We focus on simple, yet critical goals: improving your return on assets, operational performance, total cost of ownership, project time-to-benefit, and shareholder value.

All information in this report is proprietary to and copyrighted by ARC. No part of it may be reproduced without prior permission from ARC. This research has been sponsored in part by [Name of Client]. However, the opinions expressed by ARC in this paper are based on ARC's independent analysis.

You can take advantage of ARC's extensive ongoing research plus experience of our staff members through our Advisory Services. ARC's Advisory Services are specifically designed for executives responsible for developing strategies and directions for their organizations. For membership information, please call, fax, or write to:

ARC Advisory Group, Three Allied Drive, Dedham, MA 02026 USA
 Tel: 781-471-1000, Fax: 781-471-1100, Email: info@ARCweb.com
 Visit our web pages at www.arcweb.com



3 ALLIED DRIVE DEDHAM MA 02026 USA 781-471-1000

BOSTON, MA | WASHINGTON, D.C. | PITTSBURGH, PA | PHOENIX, AZ | SAN FRANCISCO, CA
CAMBRIDGE, U.K. | DÜSSELDORF, GERMANY | MUNICH, GERMANY | HAMBURG, GERMANY | TOKYO, JAPAN | BANGALORE, INDIA | SHANGHAI, CHINA